

EXPLODED DRAWING

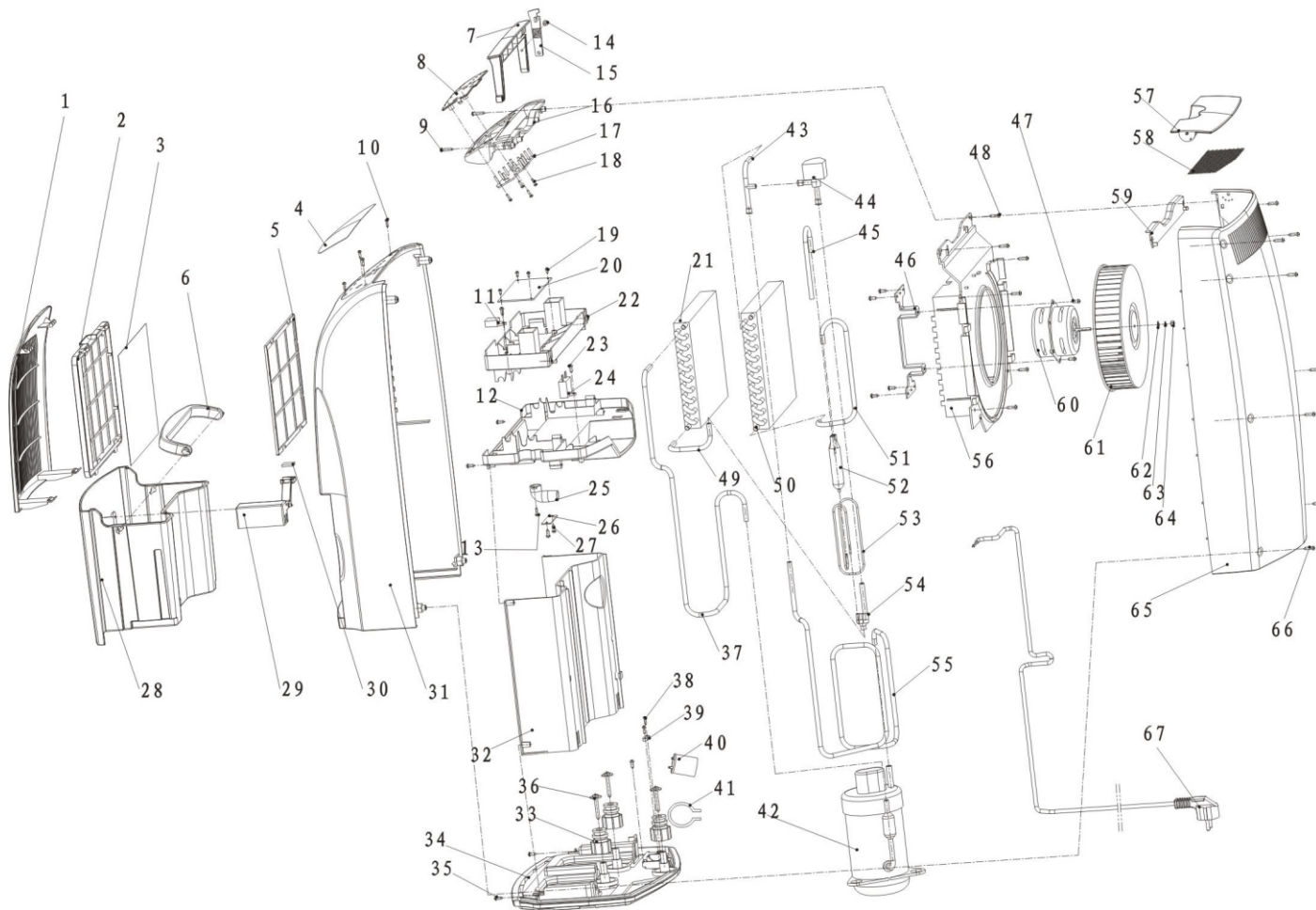

1	front panel	35	screw ST4.2X12
2	filter	36	screw ST5.0X25
3	active carbon filt	37	Retun air pipe
4	veil PVC	38	screw ST2.9X12
5	filter frame	39	terminal board for power cord
6	water tank handle	40	compressor capacitor
7	handle	41	Bracket for fixing capacitor
8	Board for fixing control board	42	compressor
9	screw ST4.2X20	43	up condense pipe
10	screw ST2.9X12	44	electromagnetic valve
11	humidity sensor	45	service pipe
12	frame	46	motor frame
13	screw ST2.9X12	47	screw ST4.2X12
14	screw ST4.2X8	48	screw ST4.2X16
15	handle piece	49	evaportor
16	handle frame	50	condenser
17	switch board	51	condense pie
18	screw ST2.9X12	52	drier filter
19	screw ST2.9X8	53	capillary tube
20	PCB	54	connect pipe
21	evaporator	55	inlet pipe
22	electrical box	56	motor frame
23	PC board frame	57	top cover
24	motor capacity	58	metal frame
25	water pipe	59	air damper
26	switch of water level	60	motor
27	screw ST4.2X12	61	lower fan
28	water tank	62	cushion
29	float levermagnet	63	spring cushion
30	magnet	64	screw M6
31	front panel	65	back board
32	bracket	66	screw ST4.2X16
33	rubber aseismatic frame of compressor	67	power cord
34	plastic base plate	68	